

Digital Level

DL600 (519006)



Content

1. Features and Functions
2. User Safety
3. Nomenclature
4. Operating Instruction
5. Application Methods
6. Self-check and Calibration
7. Technical Specifications
8. Maintenance

1. Functions and Features

DL600 (519006) is a new type of digital level, which can measure the slope angles of any plane and pipe piece, and also can provide accurate angles for indoor layout and calibration. This kind of product is featured by easy manipulation and wide applications.

Features:

- ★ Able to make angle measurement in the range of 360 degree
- ★ Able to supply graduate sound indication, convenient for construction

2. User Safety

- Do not use the instrument in corroding, flammable, exploded environment.
- Do not insert the instrument into water or make the instrument moist, in order to keep away from damage of digital circuit.
- Do not disassemble the instrument or attempt to perform any internal servicing. Repairs and servicing could be performed only by authorized service centers.



3. Nomenclature

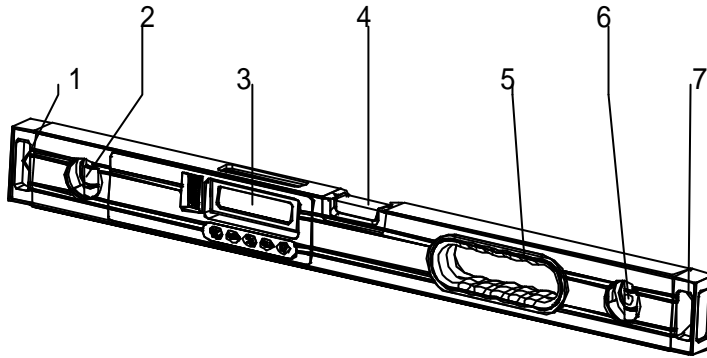

Figure 1

- | | |
|------------------|------------------|
| 1. Pothook | 5. Handgrip |
| 2. Vertical Vial | 6. Vertical Vial |
| 3. LCD | 7. Pothook |
| 4. Level Vial | |

4. Operating instruction

4.1 Battery installation

- 1) Make sure that the instrument is in power-off state.
- 2) Open the battery cap, remove the old batteries and put into the new ones.
- 3) Turn on the unit to see if all functions are correct.

Note:

- 1) Be careful of polarities when replacing the batteries.
- 2) Always take the batteries out when the instrument is not in use for a long time

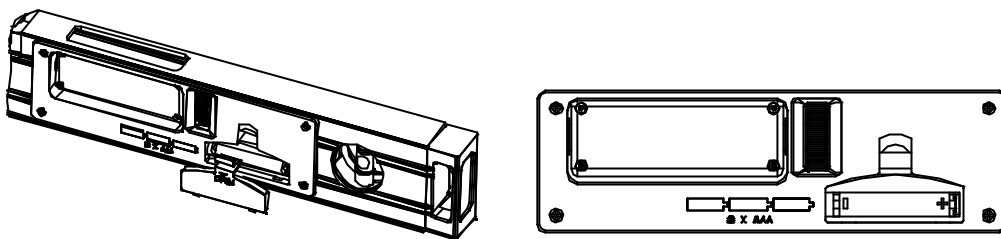

4.2 Key-press instruction

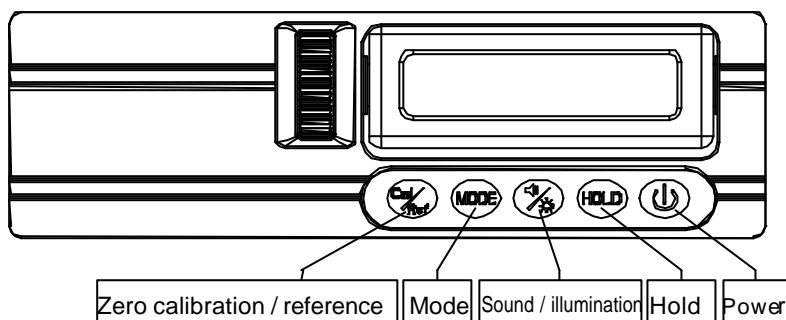

There are five key-presses in this instrument, their functions are as follow:

1. Power key [ON/OFF]

When the instrument is off, press this key to power on and after two beep sounds, the instrument begins to work normally. When the instrument is on, press this key to power off.

2. Hold key [HOLD]

Under angle measurement status, the displayed angle will vary with the slope angle. Press this key to enter into hold status, and record the current angle value with flash displaying. Then this displayed value will not change as per slope angle. Now if the sound indication is on, the sound indication is also in hold status. If press this key again, the instrument will exist the display hold status and the displayed value will vary with the slope angle.

3. Sound/illumination key

When the sound indication is off, press this key shortly to turn on the sound indication, and the sound symbol will display on the LCD. When the sound indication is on, press this key shortly to turn off the sound indication, and the sound symbol displayed on the LCD will disappear. While the sound indication is on, if the instrument is approached to the horizontal or vertical position, there will appear a beep sound as a reminder. When the instrument approaches to the horizontal or vertical position more closely, there are more indication sounds; when the instrument is exactly in the horizontal or vertical position, there are continuous indication sounds.

When the illumination status is off, long-press this key to turn on the illumination function.

When the illumination status is on, long-press this key to turn off the illumination function.

4. "Mode" switch key

Switch among five modes:

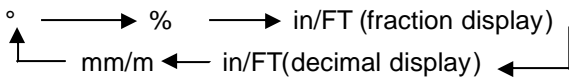

Note: Long-press this key could switch quickly.

5. "Zero calibration" key [CAL]

Long-press this key is used for calibrating the horizontal position of the instrument. Please refer to "checking and alignment" for its detailed operation procedures.

Short-press this key is used for setting the relative zero position in slope status.

Note: After setting the relative zero position, if you want cancel this setting, please power off and then power on.

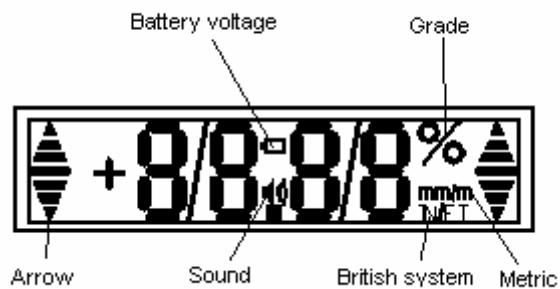

4.3 Assistant Functions

✧ Auto-off

The instrument will be auto-off in 15~20 minutes without any key-press operation.

✧ Low voltage indication

When the battery voltage is low, the battery symbol will flash in the left LCD, and then need to replace the batteries immediately.

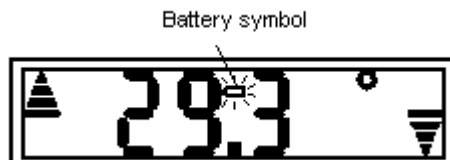

✧ Incline indication

The triangle arrows displayed in the two ends of LCD indicate the incline direction of the instrument. It could make the instrument moved to the necessary position according to the arrow indication.

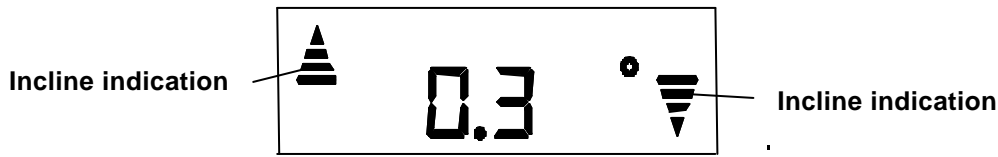

When the triangle arrows displayed in the two ends of LCD turn to the patterns showed in below figure, which indicates that the instrument is on leveling.



5. Application methods



6. Self-check and calibration

Check and calibration of reference mark would be necessary before operation for first time and temperature difference up to 10 degrees, so as to guarantee the instrument's measuring precision on grade degrees, plumb degrees or plane measurement.

6.1 Check

1.1 Find a smooth leveling plane and a smooth vertical plane. Turn on the instrument and put it on the plane, notice the LCD display, wait 10 seconds till the displayed digits stable and record the angle value.

1.2 Rotate the instrument by 180° on the same plane, wait 10 seconds again till the displayed data stable then record the second angle value.

1.3 If the difference between these two angle values is over 0.2°, it is necessary to make a recalibration for the reference mark. Check the four reference marks of 0°, 90°, 180°, 270° simultaneously. Having calibrated the reference marks, check the four reference marks again till they completely complies with the accuracy requirements.

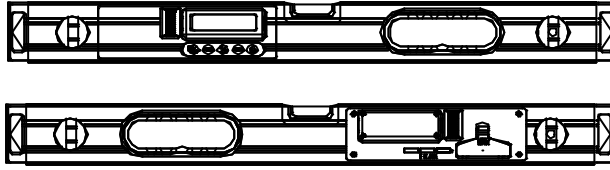

6.2 Calibration

1. Turn on the instrument and put it on a smooth horizontal or vertical surface, Press “Zero calibration” key, LCD will display “-0-“;

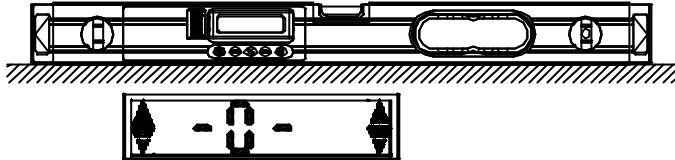

2. Wait ten seconds then press again the “Zero calibration” key, the LCD will display “-1-“;

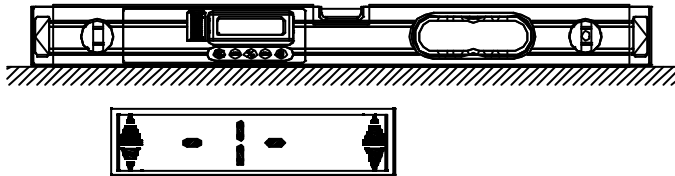

3. Rotate the instrument 180° on the same plane, wait 10 seconds and press the “Zero calibration” key again, the LCD will display “-2-“. A few seconds later, the calibration is completed and the angle value will display on the LCD.

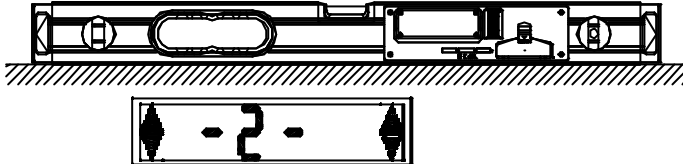

4. The calibration of other reference marks is the same as the above.

7. Technical specifications

Item	Specifications
Range of angle measurement	360 ° , Display ± 90 °
Definition rate	0.1 °
Accuracy	± 0.1 ° (Within 0 ° ~ ± 10 °) ; ± 0.2 ° (Other angles)
Power supply	3 X AAA battery
Battery life	60h
Temperature range	Operation temperature: -10 ~ +45 Storage temperature: -20 ~ +55
Vial accuracy	30' /2mm
Dimension	LS160-2: 610mm × 60mm × 28mm LS160-4: 1220mm × 60mm × 28mm
Weight	LS160-2: 488.9g (including 3 x AAA batteries) LS160-4: 1096.2g (including 3 x AAA batteries)



8. Maintenance

- ★ As a precision instrument, it should be carefully operated and properly preserved, and any violent shock or falling will possibly result in the damage of instrument.
- ★ Power off the instrument before carrying or transportation;
- ★ Do not attempt to disassemble the instrument, and the unprofessional disassembly will result in the damage of instrument;
- ★ Keep the cleanness of instrument, especially the laser output window, and remove dust by the gentle operation of soft clean cloth.
- ★ Take the batteries out when the instrument is not in use for a long time, and keep the instrument in the carrying case when it is unused.

